

- 4 cylinders
- 1372 cm³
- 26.0 kW/35.2 HP
- 3600 rpm
- Nm. 84@2000

Homologation

- EPA TIER 2 ■
- 97/68/CE Step 2 ●

Construction

- 4-stroke diesel engine with cylinders in line
- Liquid-cooled with axial fan.
- Indirect injection with injector-pump on head.
- Single-shaft distribution in head.
- Distribution control with timing belt.
- Double pto on the crankshaft.
- Pto on the distribution.
- Counterclockwise rotation.
- Forced lubrication with vane pump on the crankshaft.
- Total passage external oil filter.
- Water pump in the engine block.
- Automatic extra fuel starting device.
- Centrifugal governor.
- Torque regulator.
- Cast iron engine block with re-borable integral liners.
- Aluminium cylinder head.



Applications

- Excavator
- Dumper
- Roller
- Access platform
- Generating set
- Sweeper
- Lawn mower

Specifications

Cylinders	N.	4
Displacement	cm ³	1372
Bore	mm	75
Stroke	mm	77,6
Compression ratio		22.8:1
Rating kW/HP	N (80/1269/CEE) ISO 1585	26.0/35.2
	NB ISO 3046 IFN	24.5/33.3
	NA ISO 3046 ICXN	22.4/30.5
Max. torque	Nm.	84.0@2000
Max. torque 3 P.T.O.	Nm.	37.0@1800
Min. idling speed		900
Water pump delivery at 3600 r.p.m.	l/min.	70 (-)
Oil consumption	kg/h.	0.019
Oil sump capacity	l	3.3
Min. allowable oil pressure	bar	1.5
Max. allowable inclination for short periods of operation (peak values)		25° (35°)
Vol. of air required for correct cooling @ 3600 r.p.m.	l/min.	2470
Vol. of air required for correct combustion @ 3600 r.p.m.	m ³ /min.	88
Dry weight	kg	98
Recommended battery	V/Ah	12/44

Minimum pulley diameters for belt drive

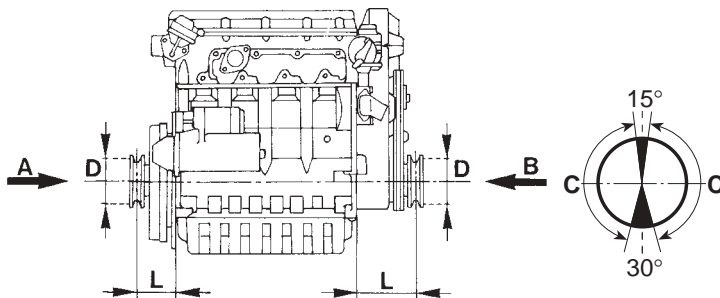

$$\text{V belt} \quad D (\text{mm}) \geq 110 [L (\text{mm}) + 101] \frac{N (\text{kW})}{n (\text{RPM})}$$

$$\text{Cogged belt} \quad D (\text{mm}) \geq 72 [L (\text{mm}) + 101] \frac{N (\text{kW})}{n (\text{RPM})}$$

Max. allowable axial load in both directions A-B = 300 kg
C - zone in which the radial load acts on the pulley



Sound pressure level dB (A)

Sound level polar diagram open field - 7 meters microphone - no load running engine.

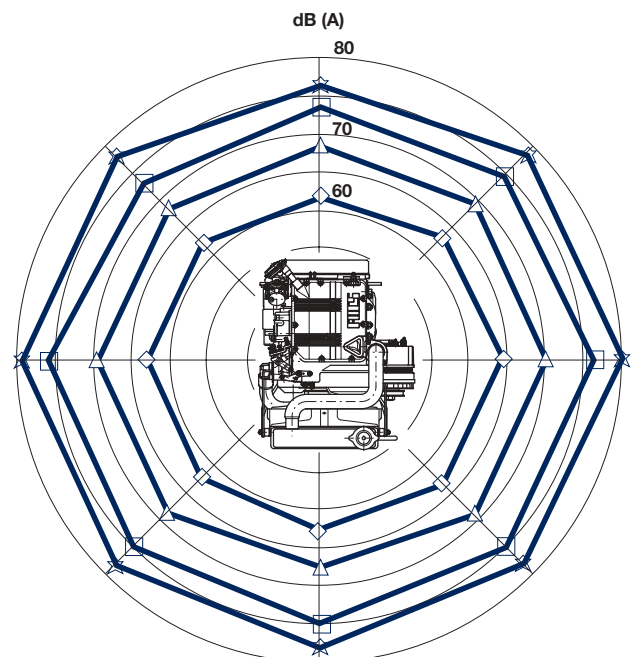

1000 RPM 2000 RPM 3000 RPM 3600 RPM

Curves

LDW 1404 @ 3600 r.p.m. ■ ●

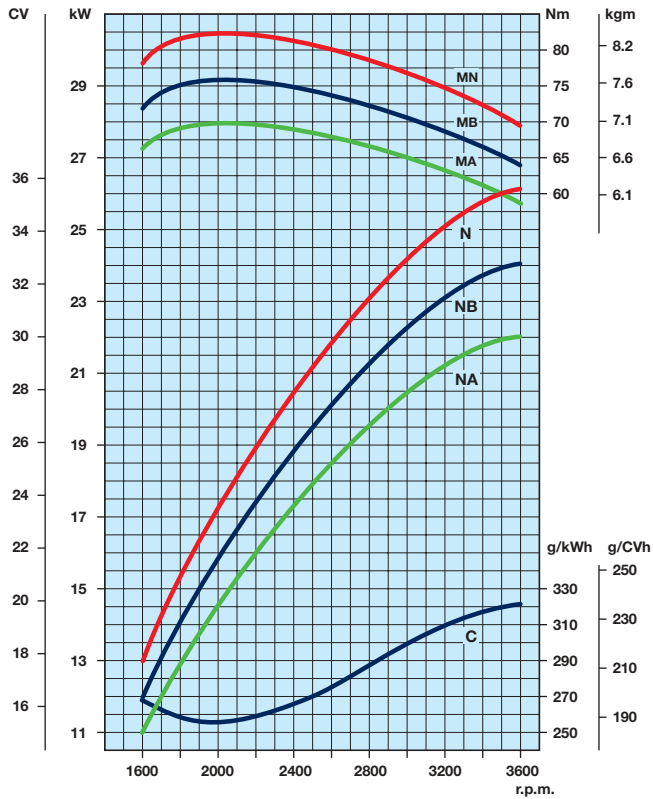

LDW 1404 B1 @ 3000 r.p.m. ■ ●

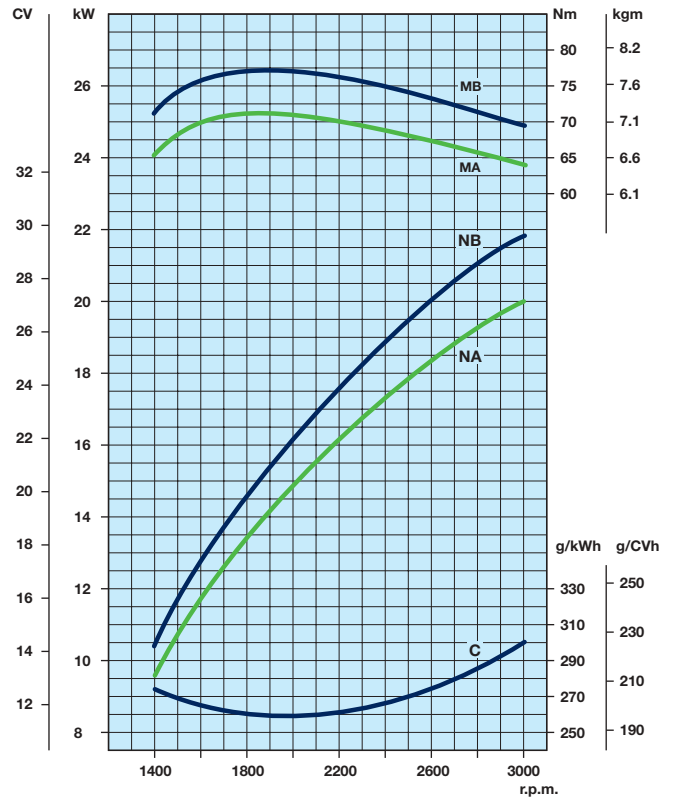

LDW 1404 B6 @ 2500 r.p.m. ■ ●

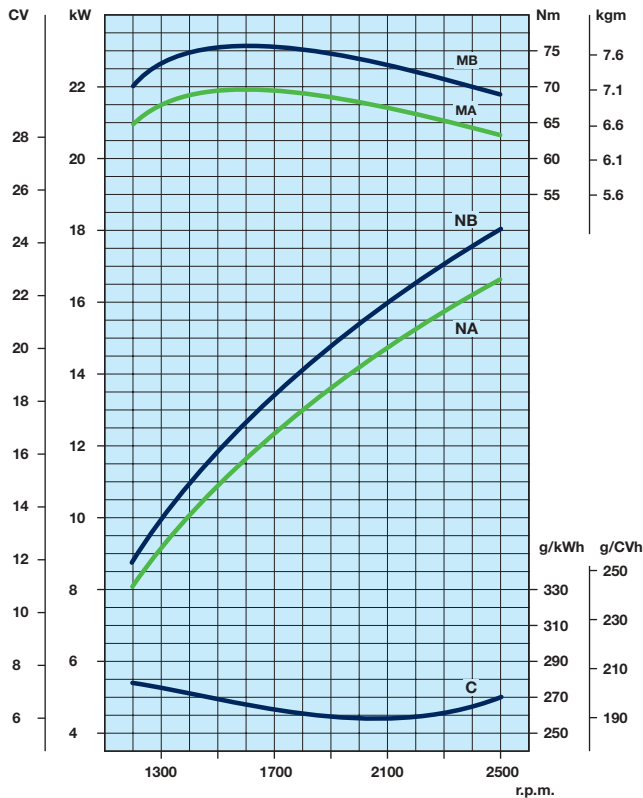

N	Power curve - 80/1269/CEE - ISO 1585 -
NB	Power curve - ISO 3046/1 - IFN -
NA	Power curve - ISO 3046/1 - ICXN -
MN	Torque curve - (N curve)
MB (B curve - MA (A curve))	
C	Specific fuel consumption - (NB curve)

Output power for fixed speed application (including generating sets)

Engine power kW

r.p.m.	Intermittent (NB)	Continuous (NA)
3600	24	21.8
3000	22	20
1800	13.5	12.3
1500	11.5	10.5

Technical drawings *

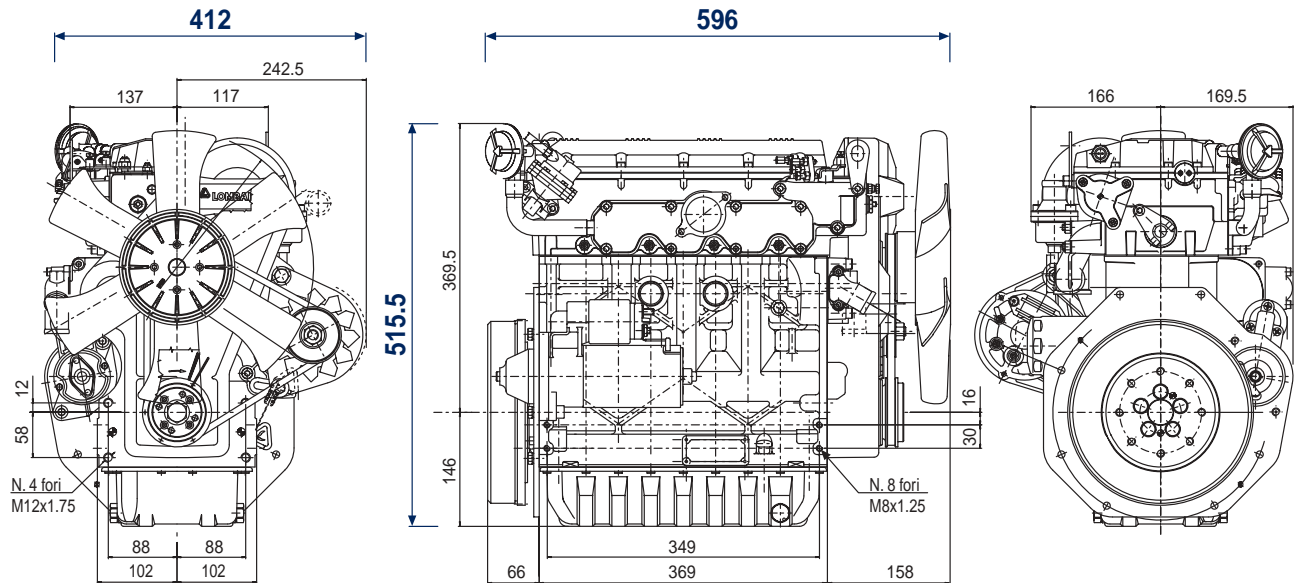

* More specific dimensions are available on www.lombardini.it (see table at the bottom of the page)

Standard equipment

- External oil filter
- Intake manifold
- Exhaust manifold
- Intake fan
- Accelerator control
- Electric starter and 12V alternator
- Thermostatic valve
- Fuel feed diaphragm pump
- Water pump
- Flanging plate
- Flywheel with ring gear
- Use, maintenance and spare parts booklet

Accessories

- Different guards according to use
- Clutch flywheels
- Flanges
- Transmission adaptors
- Keyswitch panel
- Electric stop
- Electronic plant for plugs
- Alternators 12V or 24V
- Radiators
- Blowing fan
- Engine feet
- Fuel tanks
- Mufflers
- Dry air-cleaners mounted and separated
- Cyclonic precleaners
- Fuel filter on engine
- High capacity oil sumps
- Cab heating system



ISO 9001 Cert. n. 0446 - 1405
QS. 9000 Cert. n. 2231/0



Via Cav. del Lavoro Adelmo Lombardini, 2
42100 Reggio Emilia Italia
Tel. ++39 0522.3891 Fax ++39 0522.389503
www.lombardini.it

Files for this product available on www.lombardini.it

Data sheet	LDW1404DS.PDF
Owner manual	LDW1404OM.PDF
Service manual	LDW1404SM.PDF
Technical drawing	LDW1404TD.DWG
Power curve	LDW1404PC.PDF

LOMBARDINI RESERVES THE RIGHT TO MAKE MODIFICATIONS WITHOUT PRIOR NOTICE

mod.50991/5